

USE AND CARE GUIDE

# 400 SERIES



400-P02, D02, DW2  
with





Thank you for equipping your RV or home with an Aqua-Hot hydronic heating system! We value your business and are grateful for the trust you have placed with Aqua-Hot Heating Systems Inc. Our customers are our top priority and we are committed to providing best-in-class products, service, and support.

We understand how important comfort is to you as a recreational vehicle or manufactured home owner; therefore, we have designed a heating system to significantly improve all of your comfort levels. Additionally, the Aqua-Hot hydronic heating system is a low-emissions, fuel efficient system that adds thousands of dollars in value to your RV or home.

We know you must be eager to get underway, but take time to read the entire Use and Care Guide and understand your Aqua-Hot unit. This guide should be maintained in legible condition and kept in a safe, accessible location for future review.

Should you have any suggestions how we can better serve you, please do not hesitate to contact us at +1 (800) 685-4298 or +1 (303) 651-5500.

The Aqua-Hot heating system is protected by the finest warranty in the industry (read about it on page 20.)

### **IMPORTANT NOTE:**

- A qualified installer or service technician must perform equipment installation or service. Contact Aqua-Hot for Factory Authorized Service Centers or Certified Technicians located near you at [www.aquahot.com/service-help](http://www.aquahot.com/service-help), or call us at +1 (800) 685-4298 or +1 (303) 651-5500.
- Warranty work must be performed by an Aqua-Hot Factory Authorized Service Center

### **IMPORTANT NOTE:**

- Your on-product identity label contains specifications of your unit. Factory settings may be adjusted by the RV or home manufacturer, confirm final setting with your dealer.



- If the information in this guide is not followed exactly, a fire or explosion may result, causing property damage or personal injury.



#### **Comfort Zone #1: Comfortable Cabin Heat.**

Get heat where you want it, when you want it! This Aqua-Hot system puts heat where you need it. Therefore, your interior temperatures will be just right. Don't hesitate to crank up the heat because the Aqua-Hot system doesn't remove moisture from the air. From now on, you will have to blame the dry skin and itchy eyes on Mother Nature!

#### **Comfort Zone #2: Quiet Operation**

Say goodbye to rude awakenings from the forced air furnace, you're an Aqua-Hot owner now! The Aqua-Hot is quiet when operating, so you'll never have to turn up the TV, yell across the room, or have an interrupted night of sleep again due to your heating system.

#### **Comfort Zone #3: Continuous, Hot Water**

Take long, guilt free showers knowing there is no recovery time for the next shower or load of laundry. The freedom to take a shower when you want makes your experience feel much more like home.

#### **Comfort Zone #4: Low Emissions**

Aqua-Hot's new low emission systems are fumeless and odorless. It's good for you, good for your neighbor, and good for the environment.

#### **Comfort Zone #5: Over 200 Factory-Trained Service Centers**

You won't need to service your Aqua-Hot often, but when you do, you can be confident in our Certified Service Centers that are close by and trained to assist you with all of your Aqua-Hot specific needs.

#### **Comfort Zone #6: Adds Value**

The NADA Recreational Vehicle Guide lists Aqua-Hot as adding thousands of dollars to the value of an RV. That value will pay off when it's time to trade up or sell.

#### **Comfort Zone #7: Low Fuel Costs**

There's no need to burn propane or diesel each time heat or hot water is needed. The Aqua-Hot heats a boiler tank and uses the heat stored in the liquid of the boiler tank to provide interior heat. Aqua-Hot's 200 series uses TribriidHot™ technology to power the Aqua-Hot system by pulling heat from one or a combination of heat sources. Use the electric setting to keep the boiler tank up to temperature and for light heating needs, Use the burner when colder conditions require or when using hot water.

## Contents

### Introduction

About the Aqua-Hot Heating System ..... 4  
 Safety Precautions and Instructions ..... 5  
 400P Operation and Safety Product Decal ..... 6  
 Propane Component Locations ..... 7  
 Diesel Component Locations ..... 8

### Operating Instructions

Activating the Aqua-Hot Heating System ..... 9  
 Burner and Electric Switches ..... 9  
 Interior Heating Operation ..... 9  
 Hot Water Operation ..... 9  
 Operational Flow Chart ..... 10

### Maintenance

Maintenance Schedule ..... 11  
 Replenishing the Antifreeze/Water Solution ..... 11  
 Annual Maintenance ..... 11

### Winterization and Disinfection

Winterizing the Domestic Water Heating System ..... 12  
 De-Winterizing the Domestic Water Heating System ..... 12  
 Disinfecting the Domestic Water Heating System ..... 12

### Troubleshooting

General Information ..... 13  
 Fluid Level Sensor ..... 14  
 Tempering Valve ..... 14

### Appendices

Appendix A: Antifreeze Types ..... 15  
 Appendix B: Antifreeze Mixture/Water Quality ..... 15  
 Appendix C: Antifreeze Terms and Mixture Ratio ..... 15  
 Appendix D: Measuring Antifreeze Concentration ..... 17

Owner's Service Log ..... 18

### Warranty

Limited Warranty Statement ..... 20

## Caution Notes

As you read this information, take particular note of the NOTICE, CAUTION, WARNING, and DANGER symbols when they appear. This information is important for safe and efficient use of the Aqua-Hot equipment.



**NOTICE** signals a situation where potential damage to the equipment could occur.



**CAUTION** signals a situation where potential harm or risk of minor or moderate injury could occur if instructions are not followed.



**WARNING** signals a hazardous situation where potential harm, risk of serious injury or death could result if you do not follow instructions.



**DANGER** signals a situation where immediate risk of serious injury or death will result if you do not follow instructions.

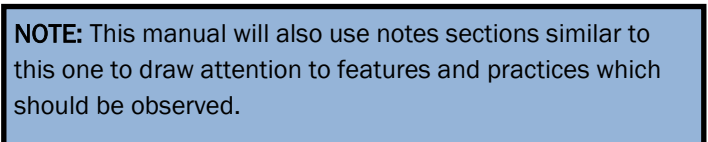

## 400 Series Features

The Aqua-Hot Heating System is a low-emissions hydronic heating system (heating with hot water) that significantly improves your level of comfort, decreases harmful emissions released into the atmosphere, and adds thousands of dollars in value to your RV.

### The Aqua-Hot Heating System is three systems in one:

1. Interior heating system
  - The interior heating system provides quiet, comfortable interior heat with independent temperature zones
2. Bay Heating System
  - The bay heating system keeps pipes and tanks from freezing in the bay storage area
3. Tank-less Hot Water System
  - Provides a steady flow of continuous hot water

### The Aqua-Hot System is a TribridHot™ technology and uses one or a combination of the following sources for heat:

1. 120V AC Electric Element
  - When plugged into shore power, or drawing power from a generator, the electric element lets you use the power you are receiving to provide heat for light-duty hot water needs
2. Burner
  - The burner is powered by either diesel or propane, and is the Aqua-Hot's most powerful heat source, and provides for all the Aqua-Hot's heating and hot water needs.

**NOTE:** This Aqua-Hot product utilizes a propylene glycol based antifreeze and water heating solution. This propylene glycol based solution is a boiler-type antifreeze that is "Generally Recognized As Safe" (GRAS) by the FDA. For additional information regarding this GRAS antifreeze product, please reference the "Care and Maintenance" section of this manual, contact the Aqua-Hot Heating Systems Technical Support Department at +1 (800) 685-4298, or visit our website at [www.aquahot.com](http://www.aquahot.com).

**NOTE:** The product label attached to the Aqua-Hot provides a ready reference to specifications, test standards, and important safety notices.

### 400P Identification Label



For installation only in a compartment that is completely closed off from living quarters and accessible only from the outdoors.

Combustion Air **MUST BE** supplied from outside the vehicle.

Suitable for water (potable) heating and space heating.

**USE COPPER CONDUCTORS ONLY!**

Use a 25-Amp fuse for over-current protection for the DC power supply.

Use a circuit breaker that cuts power at 20-Amps maximum for over-current protection for the 120-VAC power supply.

Mount the Heater near a bay/storage door so that the Access Cover can be easily removed for service.

**⚠ WARNING ⚠**

DO NOT OPERATE APPLIANCE WITH ACCESS COVERS REMOVED.

RISK OF FIRE OR ELECTRIC SHOCK. ONLY CERTIFIED OR MANUFACTURER QUALIFIED SERVICE PERSONNEL SHALL BE USED TO INSTALL AND PROVIDE MAINTENANCE OF THIS APPLIANCE.

THIS APPLIANCE OPERATES ON BOTH AC AND DC POWER.

USE ONLY NONTOXIC PROPYLENE GLYCOL BASED BOILER ANTIFREEZE WITH ADDITIVES GENERALLY RECOGNIZED AS SAFE ("GRAS") BY THE FDA.

FAILURE TO WINTERIZE YOUR HEATER, WHEN STORED IN FREEZING TEMPERATURES, WILL RESULT IN SERIOUS DAMAGE TO THE PRODUCT'S DOMESTIC HOT WATER HEATING SYSTEM.

AIR PRESSURE APPLIED TO THE TANK MUST NOT EXCEED 20 PSI. EXCESS PRESSURE WILL RESULT IN INTERNAL DAMAGE.

FOR DETAILED INFORMATION, REFERENCE THE OWNER'S MANUAL OR CONTACT AQUA-HOT HEATING SYSTEMS INC. AT 1-800-685-4298.

Minimum Heater Clearances:  
 Front - Open Access  
 Back - 1 inches  
 Top - 6 inches  
 Sides - 3 inches

This appliance must be installed in accordance with local codes or, in the absence of local codes, the Standard for Recreational Vehicles, ANSI A119.2/NFPA 1192 or CAN/CSA-Z240 RV.

**For Direct Vent Installation in a Recreational Vehicle.**

Meets or exceeds: ANSI Z21.10.1/CSA 4.1  
 UL 307B, UL 174  
 CSA-C22.2 No. 110-94

<b>0 PSI</b>	<b>5 gal</b>	<b>0.089</b>
<b>Maximum Tank Pressure</b>	<b>Tank Capacity</b>	<b>Orifice Size</b>
<b>92.5</b>	<b>1650</b>	<b>12VDC, 7.7A</b>
<b>Watts (DC)</b>	<b>Watts (AC)</b>	<b>Volts/Amps</b>
<b>120 VAC, 13.75 A, 50/60 HZ</b>	<b>55331 BTU/HR 16.2kW/h</b>	
<b>Volts/Amps/Frequency</b>		<b>Input Firing Rate</b>
<b>8" wc (in. H<sub>2</sub>O)</b>	<b>10" wc (in. H<sub>2</sub>O)</b>	<b>13" wc (in. H<sub>2</sub>O)</b>
<b>Minimum Inlet Pressure</b>	<b>Manifold Pressure</b>	<b>Maximum Inlet Pressure</b>
<b>AHE-400</b>	<b>Serial Number</b>	<b>PROPANE</b>
<b>Model Number</b>	<b>Serial Number</b>	<b>Fuel Type</b>

15549 East Highway 52 • Fort Lupton, CO 80621 • 1.800.685.4298 • [www.aquahot.com](http://www.aquahot.com)

### The Aqua-Hot Heating System

Read and understand all instructions before installing this unit.

- Read this owner's manual before installing or using the Aqua-Hot system to reduce the risk of injury to persons or damage to equipment.
- The product identity label contains specifications of the unit, to what standard it has been tested, and important safety notices.
- The Aqua-Hot must be installed in a compartment that is closed off from living quarters and accessible only from the outdoors.
- Propylene glycol based antifreeze "Generally Recognized As Safe" (GRAS) by the FDA must be utilized for antifreeze and water heating solution.
- An interlock switch prevents the Aqua-Hot heater from operating when the cover is not installed in the correct position.
- Should any additional assistance be needed, please contact the Product Application Department at +1 (800) 685-4298 or +1 (303) 651-5500.
- Do not store or use gasoline or other flammable vapors or liquids in the vicinity of this or any other appliance



- Disconnect electric wiring to the Aqua-Hot system before welding or plasma cutting the RV or home to avoid damage to equipment
- Air pressure to the tank must NOT exceed 20PSI or it will cause damage
- The Aqua-Hot exhaust is HOT and must be kept away from heat sensitive material
- Use caution when working on or near the propane gas system
- DO NOT connect the 12V DC power to the Aqua-Hot if the RV or home requires welding

- At maximum operating temperatures, the coolant will be very hot and scalding hot vapor or coolant may result in serious burns or injury
- DO NOT activate the burner until the antifreeze and water heating solution has been added to the boiler tank to avoid serious damage to the heater

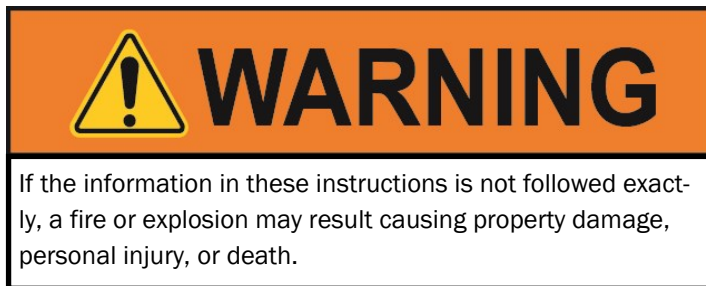

#### WHAT TO DO IF YOU SMELL GAS

- Evacuate all persons from the vehicle
- Shut off the gas supply at the gas container or source
- Do not touch any electrical switch or use any phone or radio in the vehicle
- Do not start the engine or electric generator (if equipped)
- Contact the nearest gas supplier or qualified service technician for repairs
- If you cannot contact the nearest gas supplier or qualified service technician, contact the nearest fire department
- Do not turn on the gas supply until the gas leak or leaks (if relevant) has been repaired
- Installation and service must be performed by a qualified installer, service agency or gas supplier

#### The Aqua-Hot's exhaust is HOT!

- Do NOT park in areas where dry conditions exist (i.e. grassy, dry fields)
- Do NOT operate the burner inside an enclosed building
- The heater must be switched OFF when refueling



## FOR YOUR SAFETY READ BEFORE OPERATING

**WARNING:** If you do not follow these instructions exactly, a fire or explosion may result causing property damage, personal injury, or loss of life.

- A. This appliance does not have a pilot. It is equipped with an ignition device, which automatically lights the burner. Do not try to light the burner by hand.
  - gas supplier's instructions.
  - if you cannot reach your gas supplier, call the fire department.
- B. BEFORE OPERATING, smell all around the appliance area for gas. Be sure to smell next to the floor because some gas is heavier than air and will settle on the floor.
  - C. Use only your hand to push in or turn the gas control knob. Never use tools. If the knob will not push in or turn by hand, don't try to repair it, call a qualified service technician. Forced or attempted repair may result in a fire or explosion.
  - D. Do not use this appliance if any part has been under water. Immediately call a qualified service technician to inspect the appliance and to replace any part of the control system and any gas control which has been under water.

### WHAT TO DO IF YOU SMELL GAS

- Do not try to light any appliance.
- Do not touch any electric switch; do not use any phone in your building.
- Immediately call your gas supplier from a neighbor's phone. Follow the

## POUR VOTRE SÉCURITÉ LISEZ AVANT DE METTRE EN MARCHÉ

**AVERTISSEMENT.** Quiconque ne respecte pas à la lettre les instructions dans la présente notice risque de déclencher un incendie ou une explosion entraînant des dommages, des blessures ou la mort.

- A. Cet appareil ne comporte pas de veilleuse. Il est muni d'un dispositif d'allumage qui allume automatiquement le brûleur. Ne tentez pas d'allumer le brûleur manuellement.
  - Appelez immédiatement votre fournisseur de gaz depuis un voisin. Suivez les instructions du fournisseur.
  - Si vous ne pouvez rejoindre le fournisseur, appelez le service des incendies.
- B. AVANT DE FAIRE FONCTIONNER, renifllez tout autour de l'appareil pour détecter une odeur de gaz. Renifllez près du plancher, car certains gaz sont plus lourds que l'air et peuvent s'accumuler au niveau du sol.
  - QUE FAIRE SI VOUS SENTEZ UNE ODEUR DE GAS :
    - Ne pas tenter d'allumer d'appareil.
    - Ne touchez à aucun interrupteur ; ne pas vous servir des téléphones se trouvant dans le bâtiment.
- C. Ne poussez ou tournez la manette d'admission du gaz qu'à la main ; ne jamais utiliser d'outil. Si la manette reste coincée, ne pas tenter de la réparer ; appelez un technicien qualifié. Le fait de forcer la manette ou de la réparer peut déclencher une explosion ou un incendie.
- D. N'utilisez pas cet appareil s'il a été plongé dans l'eau, même partiellement. Faites inspecter l'appareil par un technicien qualifié et remplacez toute partie du système de contrôle et toute commande qui ont été plongées dans l'eau.

## OPERATING INSTRUCTIONS

1. STOP! Read the safety information to the left on this label. If you don't smell gas, go to the next step.
2. This appliance is equipped with an ignition device, which automatically lights the burner. Do not try to light the burner by hand.
3. Ensure that the gas control valve is turned on. Follow "G" in the safety information to

the left on this label. If you don't smell gas, go to the next step.

4. Refer to the Owner's Manual for information regarding normal operation of this heating system.
5. If the appliance will not operate, follow the instructions "To Turn Off Gas To Appliance" below on this label and refer to the Owner's Manual troubleshooting section or call the technical support department at 1-800-685-4298.

## INSTRUCTIONS DE MISE EN MARCHÉ

1. ARRÊTEZI Lisez les instructions de sécurité sur la portion à gauche de cette étiquette. S'il n'y a pas d'odeur de gaz, passez à l'étape suivante.
2. Cet appareil est muni d'un dispositif d'allumage qui allume automatiquement le brûleur. Ne tentez pas d'allumer le brûleur manuellement.
3. Assurez-vous que la soupape de contrôle de gaz est bien ouverte. Passez à l'étape B des instructions de sécurité sur la portion à gauche de cette

étiquette. S'il n'y a pas d'odeur de gaz, passez à l'étape suivante.

4. Référez au Manuel du propriétaire pour des informations au sujet du fonctionnement normal de ce système de chauffage.
5. Si l'appareil ne fonctionne pas, veuillez suivre les instructions « Pour couper le gaz vers l'appareil » ci-dessous sur cette étiquette et référez à la section Dépannage du Manuel du propriétaire ou appelez le service de soutien technique au 1.800.685.4298.

## TO TURN OFF GAS TO APPLIANCE

1. Turn off all electric power to the appliance if service is to be performed.
2. Set all interior thermostats to their lowest setting.
3. Turn the gas control knob located on the heater's propane inlet port clockwise to the "OFF" position.

Turn the gas control knob located on the heater's propane inlet port clockwise to the "OFF" position.

## COMMENT COUPER L'ADMISSION DE GAZ DE L'APPAREIL

1. Coupez l'alimentation électrique de l'appareil s'il faut procéder à l'entretien.
2. Réglez tous les thermostats intérieurs à leur réglage le plus bas.
3. Tournez le bouton de contrôle du gaz, situé sur le port d'entrée de propane du chauffe-eau, vers la droite à la position « OFF » (Arrêt).

Tournez le bouton de contrôle du gaz, situé sur le port d'entrée de propane du chauffe-eau, vers la droite à la position « OFF » (Arrêt).



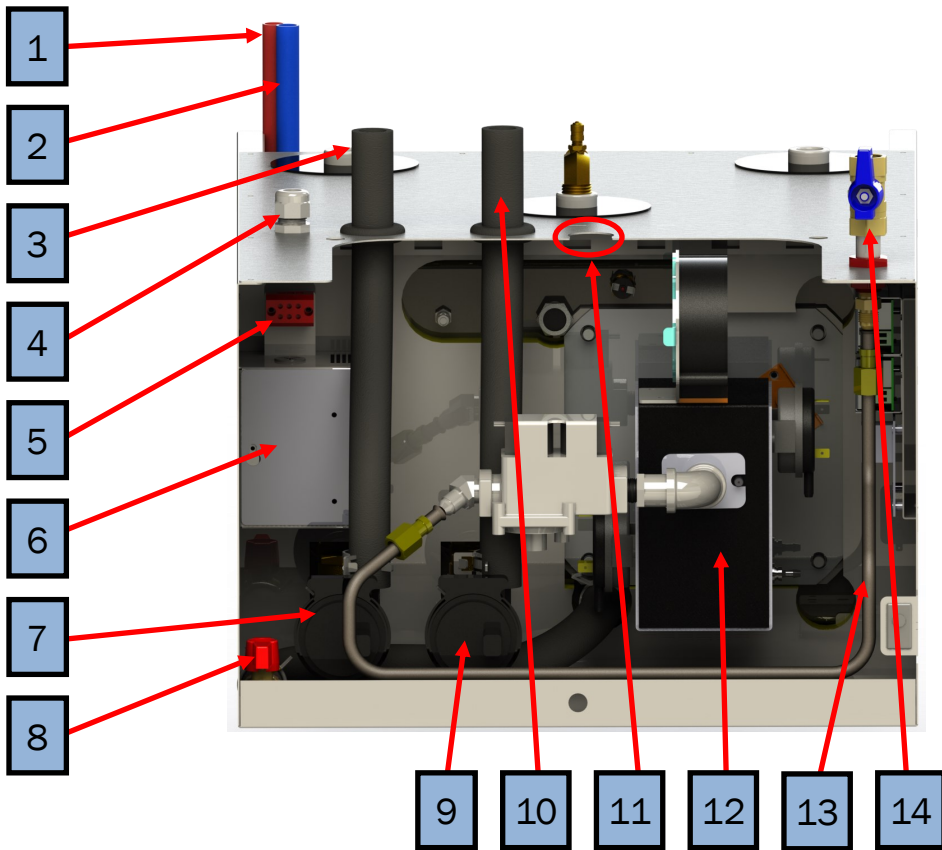

- | Components |                            |
|------------|----------------------------|
| 1.         | Domestic Hot Water Outlet  |
| 2.         | Domestic Cold Water Inlet  |
| 3.         | Heating Zone 1 Outlet Port |
| 4.         | AC Terminal Port           |
| 5.         | AC Wiring Block            |
| 6.         | AC Access Cover            |
| 7.         | Zone 1 Circulation Pump    |
| 8.         | Drain Valve                |
| 9.         | Zone 2 Circulation Pump    |
| 10.        | Heating Zone 2 Outlet Port |
| 11.        | DC Harness Port            |
| 12.        | Propane Burner             |
| 13.        | Propane Fuel Line          |
| 14.        | Propane Shutoff Valve      |
| 15.        | Air Release Valve          |
| 16.        | Expansion Tank Connection  |
| 17.        | Zone 1 Inlet Port          |
| 18.        | Zone 2 Inlet Port          |
| 19.        | Tempering Valve            |
| 20.        | Access Cover               |

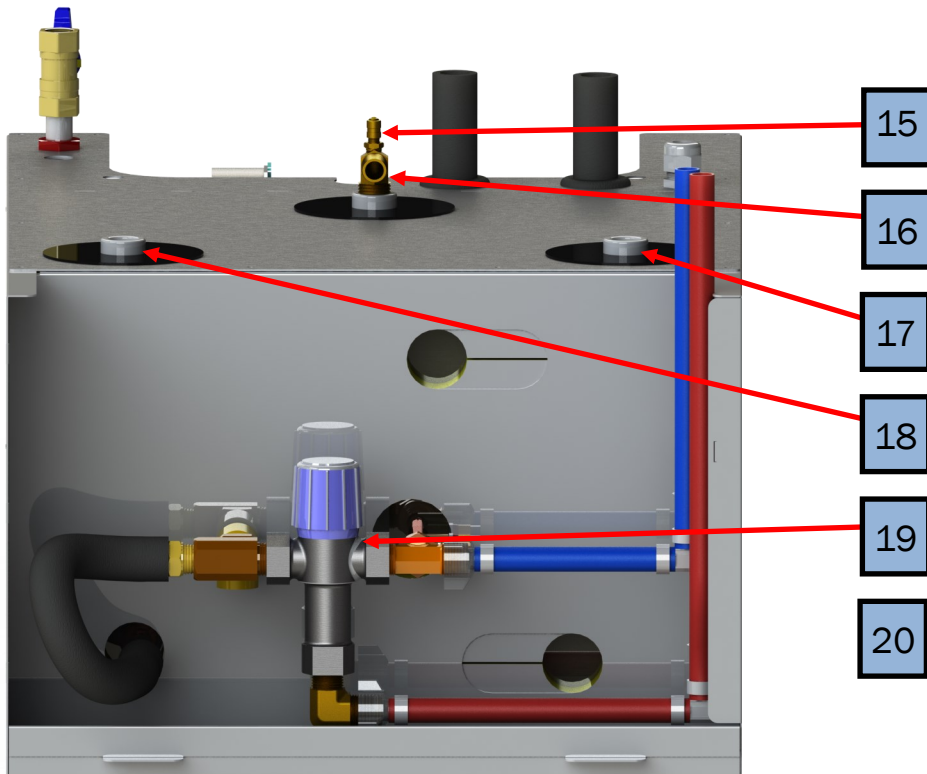

**⚠ WARNING**

The Aqua-Hot tank and heating loop operate at 0.0 PSI (zero pressure system.) Air pressure applied to the tank MUST NOT exceed 20 PSI. Excess pressure will result in internal damage.

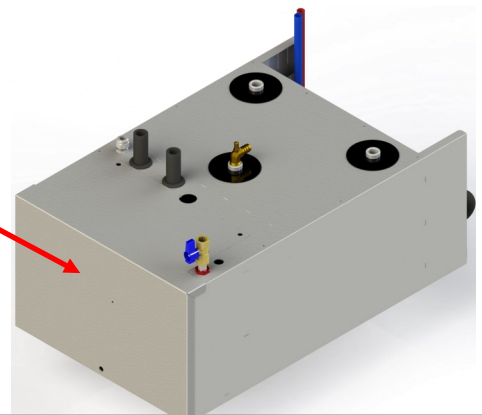

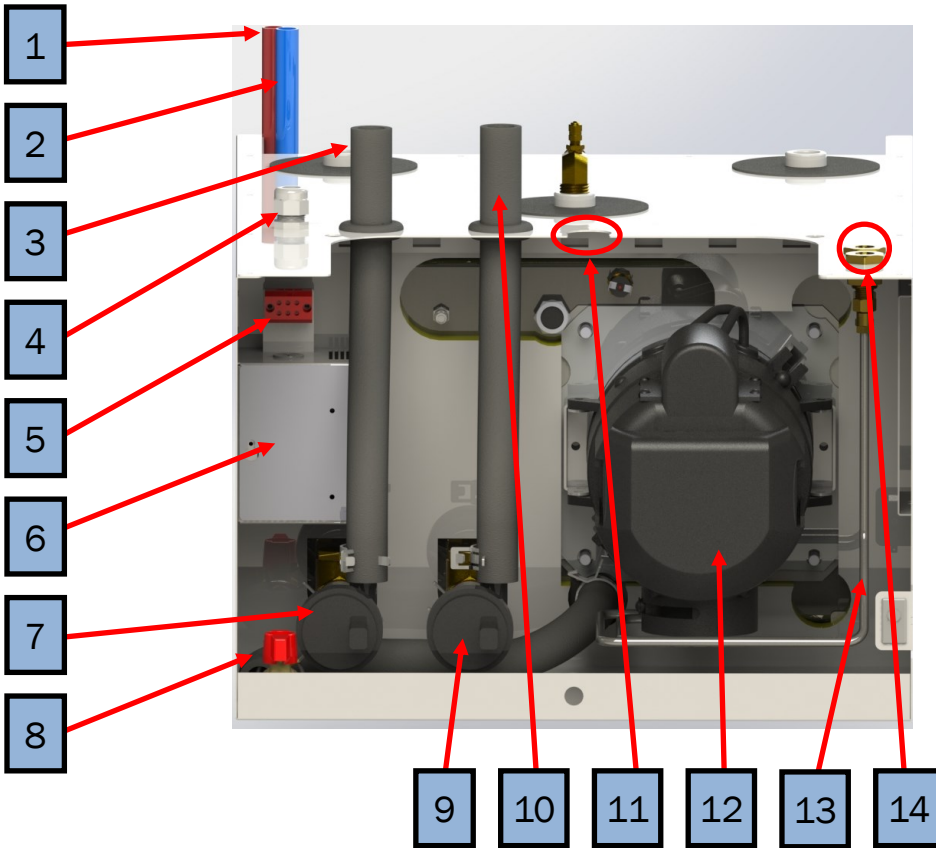

- | Components |                             |
|------------|-----------------------------|
| 1.         | Domestic Hot Water Outlet   |
| 2.         | Domestic Cold Water Inlet   |
| 3.         | Heating Zone 1 Outlet Port  |
| 4.         | AC Terminal Port            |
| 5.         | AC Wiring Block             |
| 6.         | AC Access Cover             |
| 7.         | Zone 1 Circulation Pump     |
| 8.         | Drain Valve                 |
| 9.         | Zone 2 Circulation Pump     |
| 10.        | Heating Zone 2 Outlet Port  |
| 11.        | DC Harness Port             |
| 12.        | Diesel Burner               |
| 13.        | Diesel Fuel Lines           |
| 14.        | Diesel Fuel Line Connection |
| 15.        | Air Release Valve           |
| 16.        | Expansion Tank Connection   |
| 17.        | Zone 1 Inlet Port           |
| 18.        | Zone 2 Inlet Port           |
| 19.        | Tempering Valve             |
| 20.        | Access Cover                |

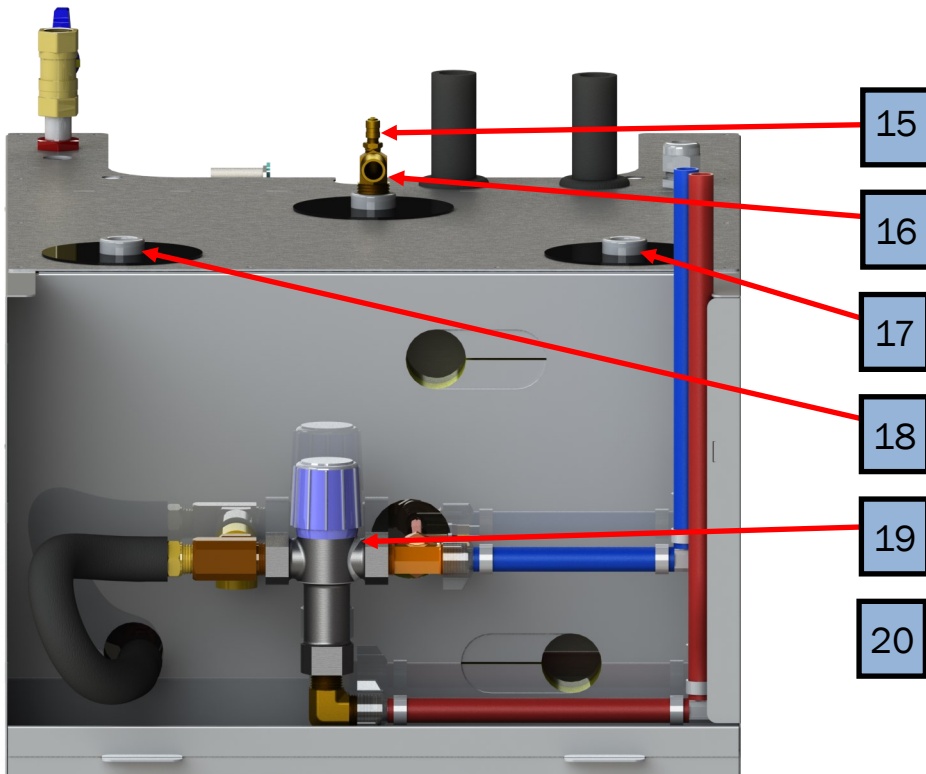

**⚠ WARNING**

The Aqua-Hot tank and heating loop operate at 0.0 PSI (zero pressure system.) Air pressure applied to the tank **MUST NOT** exceed 20 PSI. Excess pressure will result in internal damage.

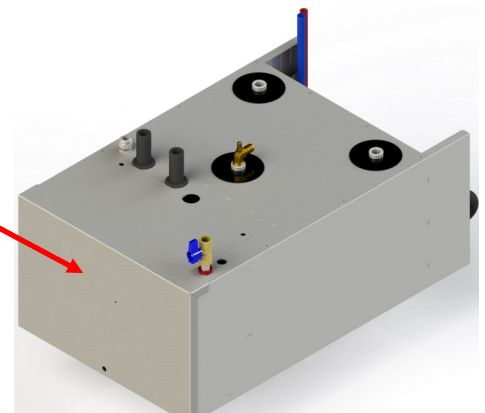

## Controls Overview

### Switches

The Aqua-Hot 400 series is controlled by two switches; the burner and electric element. When one or both of these switches are moved to the “ON” position, it will supply heat to the boiler tank to begin heating the antifreeze and water solution within. Keep in mind that the Aqua-Hot must be at operating temperature for the heating zones and hot water to function properly. It can take substantially longer to reach operating temperature if only the electric element is utilized. The location of these switches varies by coach make and model. For the exact location of these switches, contact your coach manufacturer.

## NOTICE

Do not operate the burner and/or electric element without the antifreeze and water heating solution in the Aqua-Hot’s boiler tank. Failure to adhere to this notice may cause serious damage to the Aqua-Hot.

### Thermostats

The interior room thermostat can be set at the desired temperature. Therefore, whenever the interior of the room “calls for heat,” as it were, the Aqua-Hot’s circulation pumps and interior heat exchanger fans will be activated. The fresh water thermostat controls the bay heating area, and should NOT be set below 40 °F. If the thermostat is set lower than this threshold, the risk of freezing the domestic water coil is greatly increased, and can lead to damage of your Aqua-Hot.

## Heating Operation

### Overview

The heating features are powered by a 12V DC burner and a 1650W AC electric element. These two elements, when operated separately or together will work to maintain the internal tank temperature of the Aqua-Hot, thereby providing hot water and interior heat.

- **Burner**—The burner is the Aqua-Hot’s *primary* and most powerful heating source, and provides all of the heating and hot water needs when cold temperatures exist and/or when there is a high demand for hot water or heat. This is either a diesel, or a propane burner depending on which specific model is installed in the coach. It can be activated

by turning the burner switch to the “ON” position.

- **Electric Element**—The electric element is the Aqua-Hot’s *secondary* heat source, and can be powered by either shore power, or an AC generator. The electric element provides heat when moderate temperatures exist (50 °F or higher) and/or when there is a low demand for hot water. It can be activated by moving the electric switch to the “ON” position.

### Controlling Heat Levels

The interior room thermostat can be adjusted at the desired temperature and will automatically be activated to maintain the temperature of the interior. Keep in mind that the burner and/or electric element switch on the interior switch panel must be in the “ON” position for heat to be generated.

### Control/Balancing Heat Zones

Set the interior room thermostat for each independent heating zone at the desired temperature. This feature allows you to customize various temperatures on each heating zone throughout your coach.

## Using the Water Heating System

### General Information

The Aqua-Hot system is known as an on-demand hot water heating system because hot water is not stored within the coach. Instead, when the burner and/or electric element switch is in the “ON” position, and the Aqua-Hot is at operating temperature, the water is automatically heated as it is being used. Therefore, simply open a hot water faucet once the system is up to temperature, and a continuous supply of hot water will be present within a few seconds.

### Operation Instructions

To operate the Aqua-Hot system, you will need to locate the interior switch panel located inside the coach. If you are unable to locate the switch panel, contact your coach manufacturer to guide you in locating the switch panel.

Once you have located the interior switch panel, turn the burner switch to the “ON” position. This action will activate the Aqua-Hot’s internal burner, subsequently providing heat to the antifreeze and water heating solution located inside the boiler tank.

To operate the electric heating element, again locate the interior switch panel. Move the electric switch to the “ON” position, activating the electric element. Please note that the electric element is intended as a supplemental heating source only. It is not intended to provide heat for heavy duty applications such as showering.

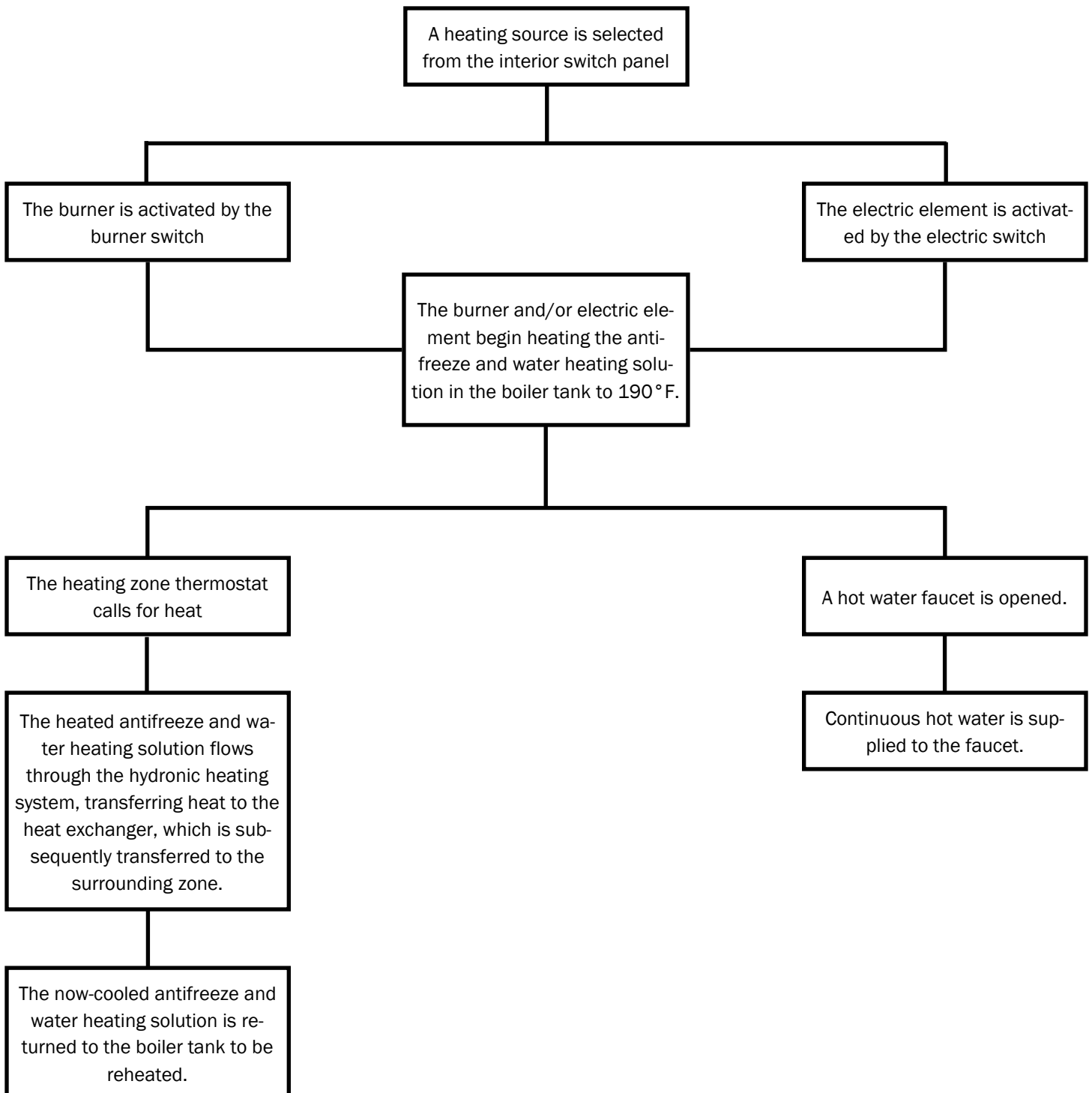

## Maintenance Schedule

### Monthly Maintenance

Check the Aqua-Hot's antifreeze and water heating solution to ensure that it is adequately filled. This is accomplished by visually inspecting the fluid expansion tank located outside of the unit. If the exact location of the expansion tank is not apparent, contact your coach manufacturer for assistance in locating it.

The fluid level should be checked ONLY when the Aqua-Hot is at maximum operating temperature, immediately after the burner cycles off.

Run the interior heating zones until you feel warm air blowing out of the heat exchangers. This will prevent the zone check valves from failing prematurely.

Run the burner at least once a month. This will ensure proper operation of the burner.

### Replenishing the Antifreeze and Water Heating Solution

If the antifreeze and water heating solution needs replenishing, remove the cap from the expansion tank and fill the tank to the "HOT" level mark.

When refilling, open the air release valve located on the expansion bottle to release air pockets. Reference Page #7, item #15. Hold this valve open until all the air is released. If necessary, refill the expansion tank again. Be sure the valve is closed when finished by hand tightening the fitting. Reference appendices A through D to ensure that the fluid inside the boiler tank is the correct ratio of antifreeze and distilled water.

### Annual Maintenance

#### 400-P02

No annual maintenance is required of this unit above the normal monthly maintenance. Reference the Aqua-Hot 400P Service and Parts manuals for spare parts information and detailed replacement instructions. Contact the Aqua-Hot Heating Systems Technical Support Department at +1 (800) 685-4298 for assistance. Otherwise, locate the nearest Aqua-Hot Service Center, or visit our website at [www.aquahot.com](http://www.aquahot.com).

#### 400-D02, 400-DW2

In order to keep the Aqua-Hot running at its full potential, it is highly recommended to have the diesel-burner tuned up annually. This consists of a new fuel nozzle,

(part #: WPX-886-41A,) and a new fuel filter (FLE-120-100.) Always use the recommended fuel nozzle and fuel filter when replacing these parts. Reference the Aqua-Hot 400 series service, and parts manuals for spare parts information and detailed replacement attachments.



## WARNING

DO NOT operate the Burner and/or the Electric Heating Element without an adequate amount of antifreeze and water heating solution in the Aqua-Hot's boiler tank. Failure to adhere to this guideline will cause serious damage to the Aqua-Hot.

Propylene glycol that is "Generally Recognized As Safe" by the FDA must be utilized for the antifreeze and water heating solution.



## DANGER

When the Aqua-Hot system is at maximum operating temperature, the coolant will be VERY HOT. If the Aqua-Hot heating system is accessed, scalding by hot vapor coolant could result. Before cleaning or servicing, disconnect all power supplies.

**NOTE:** For additional information regarding this propylene glycol based boiler-type antifreeze, reference Appendix A in this manual, contact the Aqua-Hot Technical Support Department at +1 (800) 685-4298 or visit our website at [www.aquahot.com](http://www.aquahot.com).



## Winterizing the Domestic Water System

The Aqua-Hot's domestic water heating system must be completely drained of domestic water any time the heater is stored where freezing temperatures may be experienced.

For instructions on winterizing the domestic water system, see below.

**NOTE:** The Aqua-Hot can continue to be used for interior zone heating once the domestic water heating system has been drained and winterized.

### Winterization Instructions

1. Completely drain the fresh water storage tank
2. Disconnect the domestic water demand pump's intake line from the fresh water storage tank
3. Attach an adequate piece of hose onto the suction side of the domestic water demand pump
4. Place the opposite end of the hose into an adequate supply of FDA-approved "GRAS" RV antifreeze and allow this to pump through
5. Open and close all interior and exterior water faucets, one at a time until ONLY antifreeze is flowing from the faucets.
6. Remove the hose and reconnect the domestic water demand pump intake line to the fresh water storage tank

### De-Winterization

To de-winterize the Aqua-Hot system, completely fill the fresh water storage tank, or connect the coach to a water utility outlet. Open and close the interior and exterior faucets one at a time, until only clear water is present.

### Disinfecting the Domestic Hot Water System

Aqua-Hot systems contain copper tubing, and are not compatible to prolonged exposure to sodium hypochlorite (bleach or liquid bleach.) Using products containing bleach, including water refreshers, may cause corrosion of the domestic water coil, resulting in a catastrophic failure of the Aqua-Hot system by creating leaks which cannot be repaired. Damage of this nature is not covered by the Aqua-Hot warranty.

If disinfection of the domestic water system is required, follow NFPA 1192 Standard on Recreational Vehicles **"Instructions for Disinfection of Potable Water Systems."** These instructions can be found by visiting the National Fire Protection Association online at [www.nfpa.org](http://www.nfpa.org).

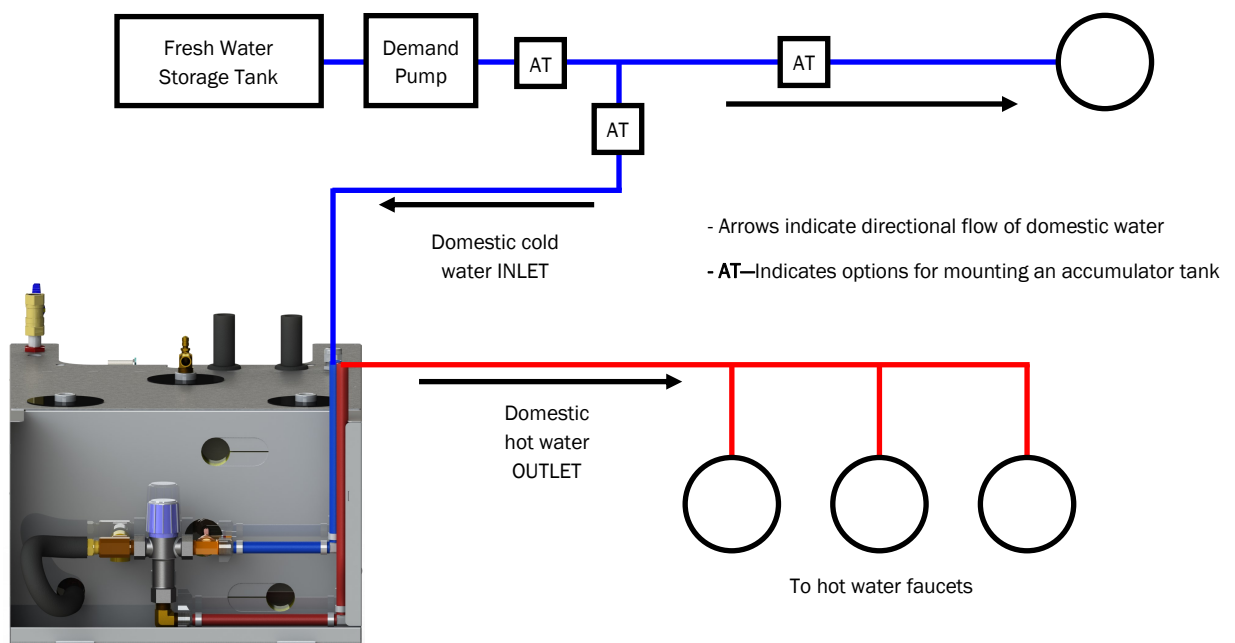

## General Information

Your new Aqua-Hot 400 Series unit contains the Aqua-Hot Reporter, a replacement for our previous electronic controllers.

Should the Aqua-Hot heating system fail to operate, complete the following steps:

1. Verify that the Aqua-Hot's access cover is securely installed. Reference page 7, part #20. The Aqua-Hot will not operate if the access cover is not installed, or installed incorrectly.
2. Ensure that the vehicle's fuel tank contains a sufficient level of fuel.
3. Ensure that the Aqua-Hot's boiler tank has an adequate supply of antifreeze and water heating solution by checking the level at the expansion tank.
4. Check the Reporter "FAULTS" screen, and record and fault conditions which are noted.

If the Aqua-Hot's operational failure is not resolved with the aforementioned checks, please contact the Aqua-Hot Heating Systems Technical Support Department at +1 (800) 685-4298 for additional assistance, or visit our website at [www.aquahot.com](http://www.aquahot.com).

If the Aqua-Hot's burner switch "indicator light" does not illuminate and the burner is not functioning, locate the Reporter, and perform the following actions.

### Heartbeat Function

Aqua-Hot Reporter units with firmware version 5 and later are equipped with a "heartbeat" function which establishes a signal between the RVC system and the Reporter. The Reporter will be constantly awaiting a signal from the RVC network indicating to the Reporter that it is to continue normal operation. Loss of 6 consecutive signals from the RVC network will trigger the Reporter to de-activate the Aqua-Hot.

This serves as a safety feature to ensure that the Aqua-Hot does not continue to operate if the coach loses power. Once

**NOTE:** An interlock switch prevents the Aqua-Hot from operating when the cover is not installed, or installed improperly.

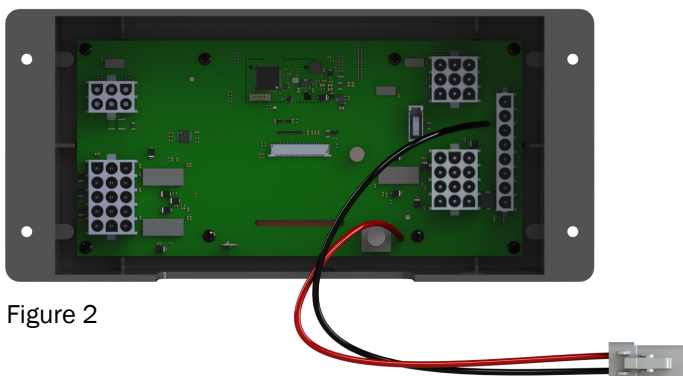

Figure 2

power is restored to the coach and the Reporter unit, "BATTERY DISCONNECT SWITCH OFF" will be displayed in the fault log, indicating that the Reporter has lost connectivity with the RVC network.

## Reporter Diagnosis

1. Check the Reporter fault screen for any fault conditions associated with this unit (Figure 1.) Record these conditions.
2. Check for loose wire connections on the Reporter by removing the four bolts or screws securing the housing to its mounting position. It may be necessary to check with your coach manufacturer to determine the best way to remove the Reporter. Do NOT remove the circuit board from the housing.
3. Remove the Reporter and ensure that all connections are secured, and that the wires are in good condition Reference Figure 2.
4. Ensure the vehicle's fuel tank has a sufficient level of fuel.
5. If the Aqua-Hot still fails to operate, please contact the Aqua-Hot Heating Systems Technical Support Department at **1-800-685-4298** or visit our web site at [www.aquahot.com](http://www.aquahot.com).

The Aqua-Hot Reporter contains both a fault page, and a fault log. The fault page contains information on faults that have occurred since the last time the Reporter was reset or power cycled. The fault log cannot be cleared and can contain up to four historic fault conditions not necessarily related to a present issue.

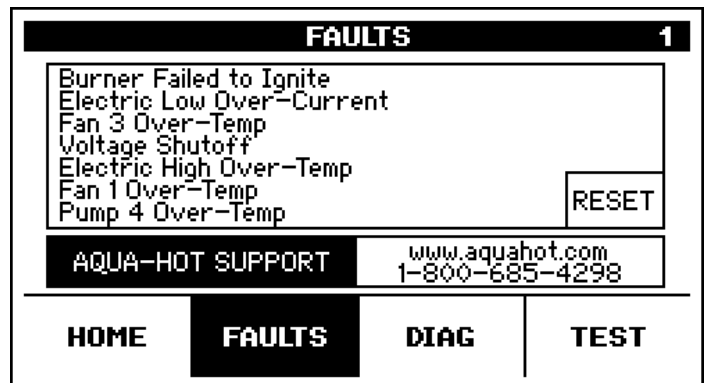

Figure 1



Figure 3



## Testing Functionality

### Fault Conditions

The Reporter will display the following fault conditions accompanied by the component which caused the fault (pump, fan, burner, etc.)

### Over-Current

An Over-Current fault condition occurs when too much current is drawn by a component, usually a fan, or pump (output channel.) When this fault is triggered, the output channel is shut off until the Reporter has been reset or power cycled.

### Over-Temperature

An over-temperature fault will occur only if any particular channel within the Reporter has reached an over-current condition. The error message will be accompanied by the component which caused the over-temperature condition.

### Low Voltage

The Reporter is designed to operate between 11V Direct Current (DC), and 16V DC current. If the Reporter detects that it is receiving voltage below 11.8V DC, a System Voltage fault will trigger, and display on the screen. If the Reporter system drops below 11.2V DC for thirty (30) seconds, it will discontinue operation of your Aqua-Hot heating system.

### Low Level Cut Off

If the system senses low fluid level, the heating system will shut down all fans, heat sources, and pumps until the unit is refilled.

### Ignition Failure

An ignition failure fault occurs if for some reason the burner fails to ignite.

### Test Functionality

The Reporter has been designed to include a host of test features allowing for quicker diagnosis and repair of components. Using the “PREVIOUS” and “NEXT” buttons on the test screen, it is possible to cycle between the burner and electrical sub-systems, zone fans, and pumps. The tests are sorted into different screens; TESTING—PUMPS, TESTING—HEAT, TESTING—FANS. Only one screen of tests may be used at any one time. Starting a pump test, then switching to the TESTING—FANS screen will deactivate the pump test. In addition, the Reporter will “time-out” after five minutes of non-interaction, returning to the home screen. This will disengage any tests currently in progress.

### Pumps and Zone Fans

Pumps and zone fans are activated individually, and remain so until the Reporter times out, or the test is manually ended.

### Heating Subsystem

The Reporter will allow the electric and burner sub-systems to be activated and run for a maximum of five minutes to verify functionality of those systems. Please note that if used im-

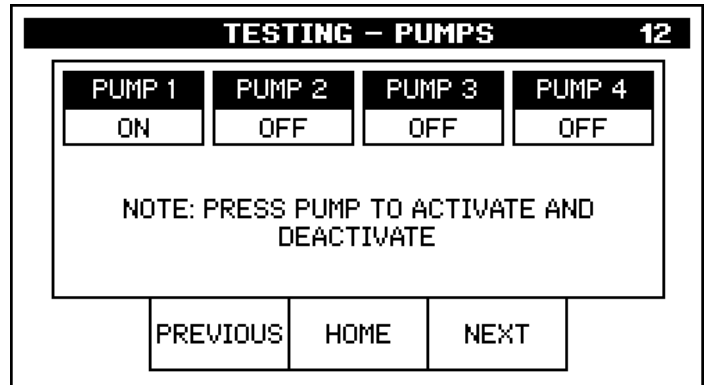

properly, this testing tool could cause damage to your Aqua-Hot unit and the heating subsystem test is NOT a replacement for standard unit operation. If you have any questions, please don't hesitate to contact the Aqua-Hot technical support department at **1-800-685-4298**.

## Tempering Valve

The Tempering Valve for the Aqua-Hot mixes the heated domestic water from the boiler tank with cold domestic water at the present ratio to reduce the risk of scalding. This valve is located in the back of the Aqua-Hot unit. Reference page 7 (part #19).

To locate the Tempering Valve, remove the access cover page 7 (part #20) and then the thermostat access cover located above the burner. Reference page 7 (part # 19). The pink paint witness mark verifies that the Aqua-Hot is set at the correct factory setting and did not get tampered with during shipping or installation.

Verify that the Tempering Valve is set at the proper temperature by using a digital thermometer at one of the hot water faucets. The water temperature should range between 115°F to 123°F. If the correct temperature cannot be set, please contact Aqua-Hot Heating Systems Technical Support Department at **1-800-685-4298** for additional assistance or visit the web site at [www.aquahot.com](http://www.aquahot.com).

## Appendix A: Antifreeze Types

The following information addresses the necessary usage of propylene glycol based “boiler” type antifreeze in the Aqua-Hot. Propylene glycol is a safer alternative to the more toxic ethylene glycol antifreeze; however, as mandated by the International Association Plumbing and Mechanical Officials (IAPMO,) only propylene glycol based “boiler” type antifreezes deemed “Generally Recognized As Safe” (GRAS) by the FDA should be utilized.

Due to the significant impact of various types of antifreeze on a hydronic heating system, including the level of safety provided, it has been recognized that there is a need to provide an explanation regarding two additional prominent types of antifreeze/coolant available. The following information should be utilized as an educational means of ensuring that the proper type of propylene glycol based antifreeze is selected.

### RV & Marine Antifreeze

These types of propylene glycol based antifreeze products are formulated specifically for “winterizing” applications ONLY. Although RV and Marine antifreeze is often GRAS approved by the FDA, it should never be used in the Aqua-Hot’s Hydronic Heating System. This type of antifreeze is not formulated to transfer heat, which is essential to the heating system’s functionality and does not contain rust inhibitors. Please note that RV and Marine antifreeze can be utilized to winterize the Aqua-Hot’s domestic water coil for extended storage periods.

### Automotive Antifreeze/Coolant

These types of propylene glycol based antifreeze products are formulated specifically to protect automotive engines against corrosion, freezing temperatures, and overheating. They also have excellent heat transfer and thermal conductivity characteristics. Although these types of antifreeze products are considered less toxic and safer than ethylene glycol for people, pets, and the environment, they are not GRAS rated by the FDA. Therefore, they must be marked with a “harmful if swallowed” warning. This additional warning is required because these types of antifreeze products contain high levels of chemical rust inhibitors. Due to their potentially hazardous properties, they should never be used in an Aqua-Hot heating system.

## Appendix B: Antifreeze Mixture Water Quality Recommendations

In order to ensure maximum performance and longevity of an Aqua-Hot heating system’s boiler tank and associated components, it has been determined that there is a need to use distilled, de-ionized, or soft water in combination with concentrated propylene glycol for the Aqua-Hot’s antifreeze and water heating solution. Please note that this is only necessary when mixing concentrated propylene glycol antifreeze with water; suppliers of pre-mixed antifreeze are responsible for the use of high-quality (distilled, de-ionized, or soft) water when preparing their antifreeze for sale.

Hard water possesses a high-level of calcium and magnesium ions, which deplete the corrosion inhibitors in the propylene glycol. This causes the antifreeze and water heating solution to begin turning acidic, which can corrode the Aqua-Hot boiler tank and domestic water coil prematurely, thereby shortening the operational lifespan of the Aqua-Hot. Therefore, concentrated propylene glycol should be used with distilled, deionized, or soft water. The local water agency should have up-to-date water quality reports which will indicate if the local tap water is within our guideline of 80ppm of hardness or less.

## Appendix C: Antifreeze Terms and Mixture Ratio

The following information addresses the process of selecting a propylene glycol based antifreeze solution that provides adequate freeze, boiling, rust, and corrosion protection. A 50/50 mixture ratio is recommended, which will result in a freeze point of approximately  $-28^{\circ}\text{F}$  and a boiling point of approximately  $222^{\circ}\text{F}$ .

The following information should be utilized for the purpose of clarifying some terms commonly associated with antifreeze.

### Freeze and Burst Point

Antifreeze solution lowers the freezing point of any liquid to which it has been added by preventing the formation of crystals. However, as the ambient temperature continues to decline, the water in the solution will attempt to attain a solid state. The point at which the water begins to solidify (or “gel”) is termed as the “freeze point.” Although the water in the solution has begun to freeze, producing a “slushy” consistency,

the antifreeze in the solution will continue to combat the normal expansion of the solution as it freezes. The point in which the solution can begin to expand due to colder temperatures is called the “burst point.” Once the solution reaches the burst point, the potential is present for ruptured pipes to exist. The burst point of the antifreeze and water solution is dependent upon the brand of propylene glycol antifreeze employed.

**Boiling Point**

The Aqua-Hot utilizes the propylene glycol based (PPG) antifreeze and water heating solution as a transportation means for the heat produced from the internal processes. The PPG antifreeze solution absorbs the heat created until its boiling point is reached. It is at this point when the liquid turns to a gas and is expelled to prevent the heating system from overheating. Each time the boiling point is reached, a loss of efficiency occurs because the heat produced is expelled rather than utilized for the function of the heating system. Therefore, a higher boiling point is desired in order to combat the loss of efficiency, which allows the antifreeze to transport the heat created from the internal process throughout the motorhome where it can be utilized productively rather than dissipating due to its change from a liquid to a gas.

**Rust and Anti-Corrosive Inhibitors**

Another major function of the antifreeze solution is to protect the internal metal components of the Aqua-Hot system from corrosion and rust. Antifreeze is able to perform this function by the addition of rust and corrosion inhibitors, which are designed specifically to activate in a water solution.

**Summary**

Antifreeze solution has three basic functions

1. Freeze Protection
2. Boil-over Protection
3. Anticorrosion and Rust Protection

PPG antifreeze solution is also primarily responsible for heat transfer; however, propylene glycol itself does not possess acceptable heat transfer characteristics. Therefore, water is added to the mixture due to its nature as an excellent heat conductor. PPG antifreeze solution, mixed with water that is 35% to 50% propylene glycol is recommended to provide the best performance combination of the aforementioned functions. If excess propylene glycol exists within the antifreeze and water heating solution, the water’s heat absorption properties will be compromised. This could ultimately inhibit the Aqua-Hot from providing adequate domestic hot water and interior heating.

Additionally if the antifreeze and water heating solution contains over 70% propylene glycol, the freezing point is raised, resulting in less freeze protection. Please reference the attached graphical representation regarding percentage of antifreeze to water and how it directly affects the solution’s freezing point.

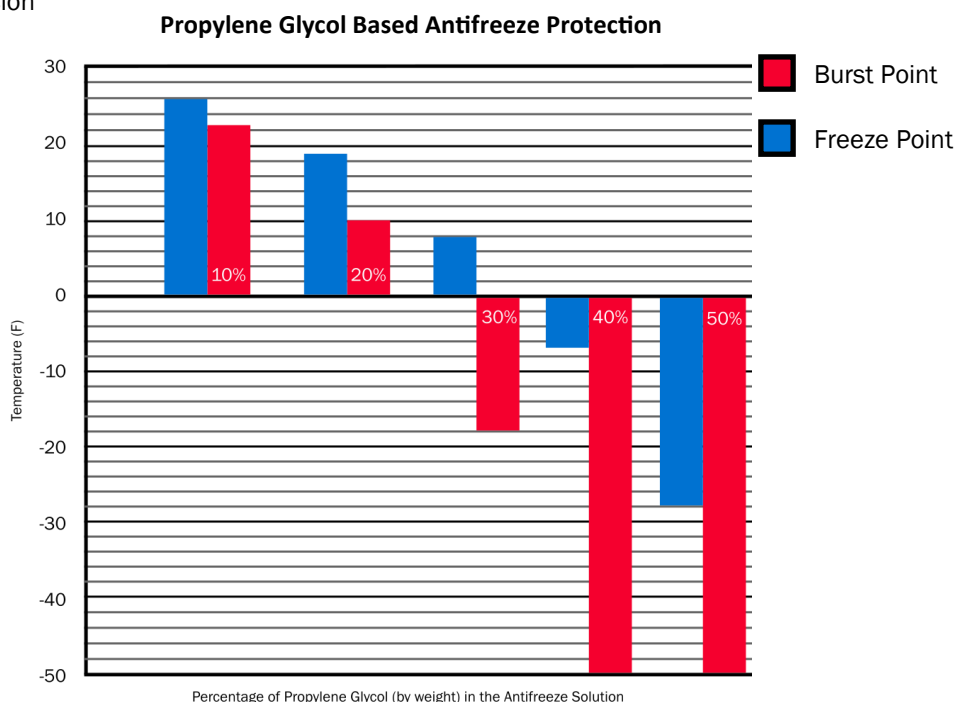

## Appendix D: Measuring Propylene Glycol Using a Refractometer

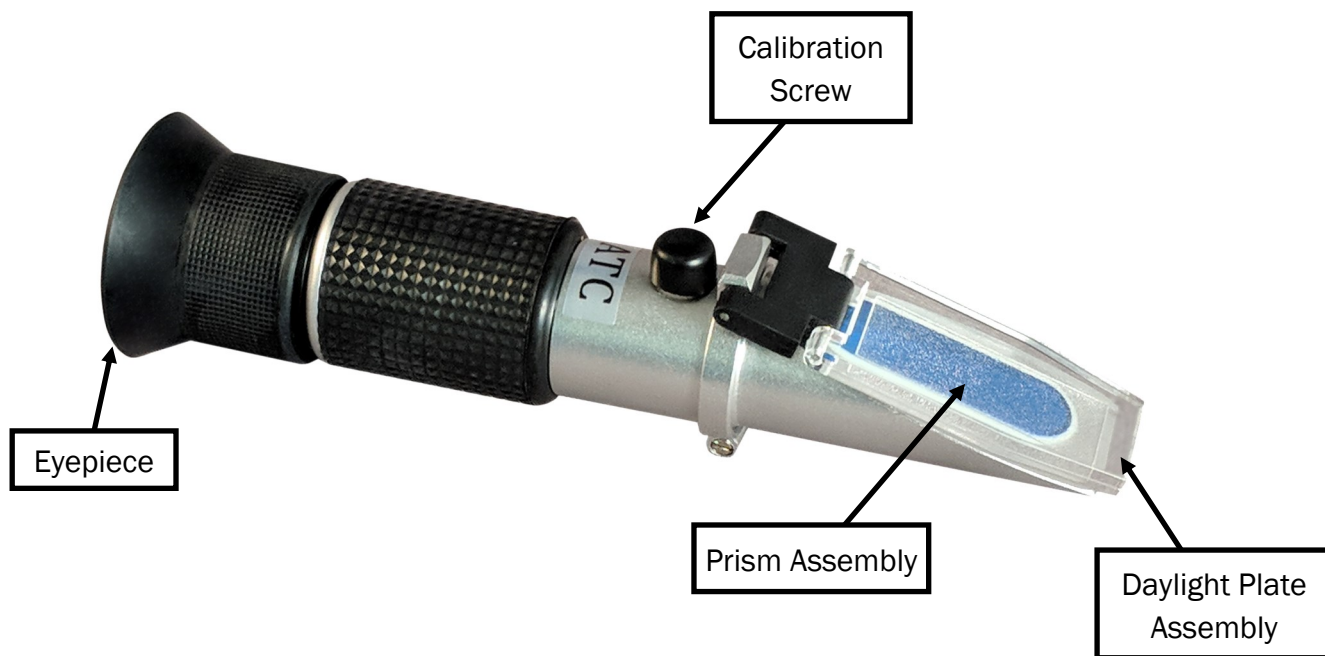

### Properly Apply Antifreeze to the Prism Assembly

Use the guide below to properly apply the propylene glycol mixture to the prism assembly of the refractometer. Once that is complete, peer through the eyeglass of the refractometer to continue to the next step.

### Adjust the Boundary Line

Once the glycol solution has been properly applied, adjust the calibration screw until the boundary line labelled "Propylene Glycol" is set to 32 °F. The graphic to the right has been designed as an aid, but note that it may differ from what is shown in the refractometer sight glass.

### Application of Propylene Glycol

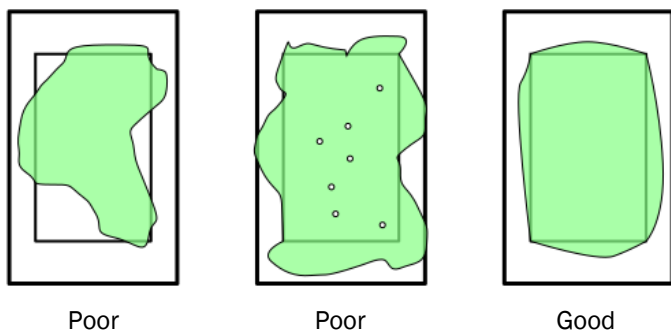

### Refractometer Sight Glass

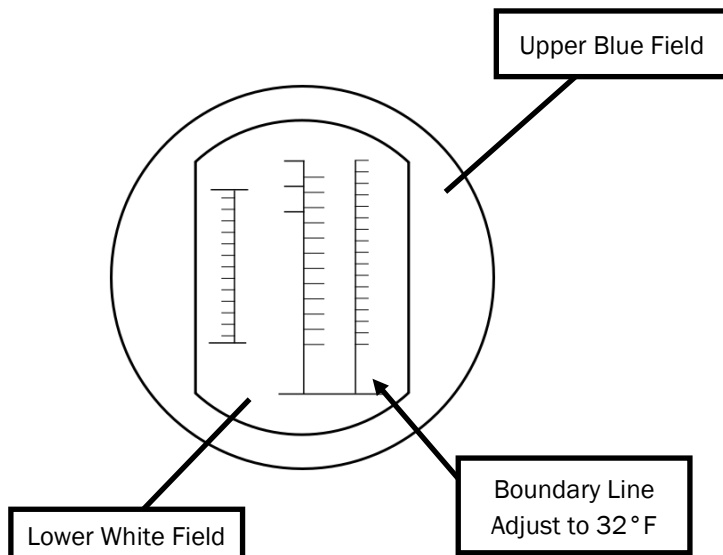

DATE	SERVICE PERFORMED	SERVICE CENTER

Service Log

DATE	SERVICE PERFORMED	SERVICE CENTER



## 2-YEAR LIMITED WARRANTY AQUA-HOT® HYDRONIC HEATING SYSTEM

Aqua-Hot Heating Systems Inc. warrants the Aqua-Hot Heater to be free from defects in material and workmanship under normal use and service for a period of two years on both parts and labor commencing upon the original date of registration of the vehicle. Replacement parts are warranted for the remainder of the Heater's standard warranty coverage or for six months, whichever is greater. The intent of this warranty is to protect the heater's end-user from such defects, which would occur in the manufacturing of the product. Thus, problems due to improper specifications, improper installations, improper use, the use of accessory parts or parts not authorized by Aqua-Hot Heating Systems Inc., repair by unauthorized persons, and damage or abuse of the heater are specially excluded from warranty coverage.

For additional information, or to obtain a warranty repair authorization, please contact the *Aqua-Hot Heating Systems Warranty Administrator* at 1-800-685-4298 (7:00 AM to 4:00 PM Mountain Standard Time) or visit [www.aqua-hot.com](http://www.aqua-hot.com).

### **My Comfort Zones are On-Board**

Vehicle:

### **Purchased From:**

Dealer Information:

Name:

Location:

Phone Number:

### **Heating System:**

Serial Number:





LTE-907-608 Rev. B

# 400 SERIES

 **Aqua-Hot**®

400-P02, 400-D02 & DW2



Aqua-Hot Heating Systems, Inc.  
7501 Miller Drive, Frederick, CO 80504

Visit us on line at [www.aquahot.com](http://www.aquahot.com)  
Call us at (800) 685-4298 or (303) 651-5500

©2018 Aqua-Hot Heating Systems Inc. Printed In U.S.A.